

### MATERIAL SPECIFICATIONS&PARTS

NO.	PART NAME	MATERIAL	MATERIAL
1	Body	A216 WCB	A351 CF8M
2	Seat	SS304+STL	SS316+STL
3	Seat Retainer	A216 WCB	A351 CF8M
4	Disc	4800+Cr	SS2205+Cr
5	Bolt	A193 B7	A193 B8M
6	Packing	PTFE+SI	PTFE+SI
8	Packing Gland	A193 B7	A193 B8M
7	Bolt	A216 WCB	A351 CF8M
9	Pin	A276 420	A276 420
10	Stem	A276 420	A276 420
11	Yoke	CS+Cr	CS+Cr
12	Top Mount	WCB	WCB
13	Stem Nut	AQ19-4	AQ19-4
14	Handwheel	Cast Iron	Cast Iron
15	Bolts	A193 B7	A193 B7
16	Gear	Assembly	Assembly

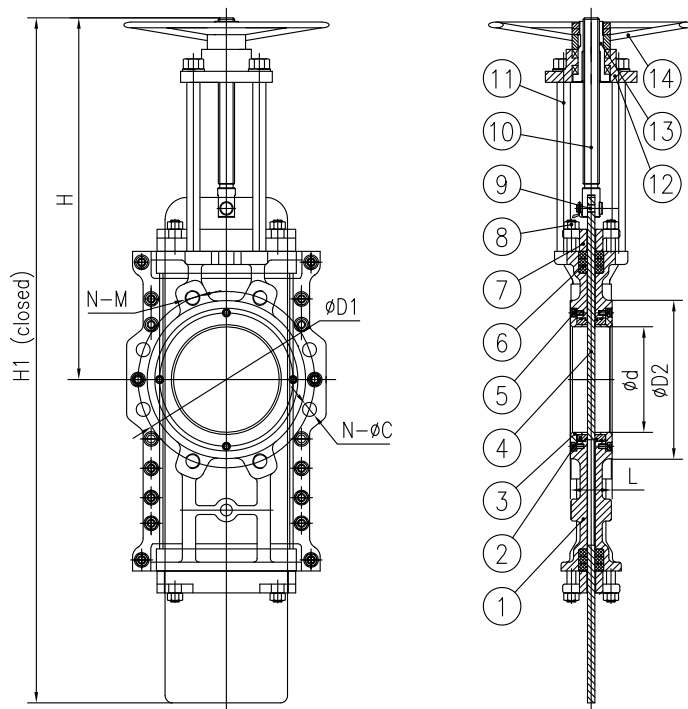

SIZE:DN50-DN150

### TESTING SPECIFICATION

- 1.BODY TEST: 1.5 TIMES RATING PRESSURE BEFORE ASSEMBLY
- 2.SEAT CLOSURE TEST PRESSURE: 2.8 BAR BY WATER
- 3.LEAKAGE RATE COMPLY WITH MSS SP-81

✧ END CONECTION OPTIONS: ASME B16.5; GOST12815;

✧ OPERATION OPTIONS: PNEUMATIC; ELECTIC ACTUATOR;

### VALVE DIMENSIONS (EN1092-1 PN10)

DN	L	Ød	ØD1	ØD2	N-M	N-ØC	H	H1
50	48	45	125	90	4-M16	-	305	480
65	48	62	145	120	4-M16	4-18	355	635
80	51	90	160	132	4-M16	4-18	365	705
100	51	95	180	156	4-M16	4-18	420	750
125	51	116	210	186	4-M16	4-18	460	870
150	57	144	240	211	4-M20	4-22	505	950
200	70	190	295	266	4-M20	-	620	1400
250	70	240	350	319	8-M20	-	740	1710
300	76	285	400	370	8-M20	-	830	2000
350	76	330	460	429	12-M20	-	930	2260
400	89	380	515	480	12-M24	-	1090	2730
450	89	440	565	532	12-M24	-	1180	2820
500	114	480	620	582	16-M24	-	1450	3400
600	114	570	725	682	16-M27	-	1850	4120

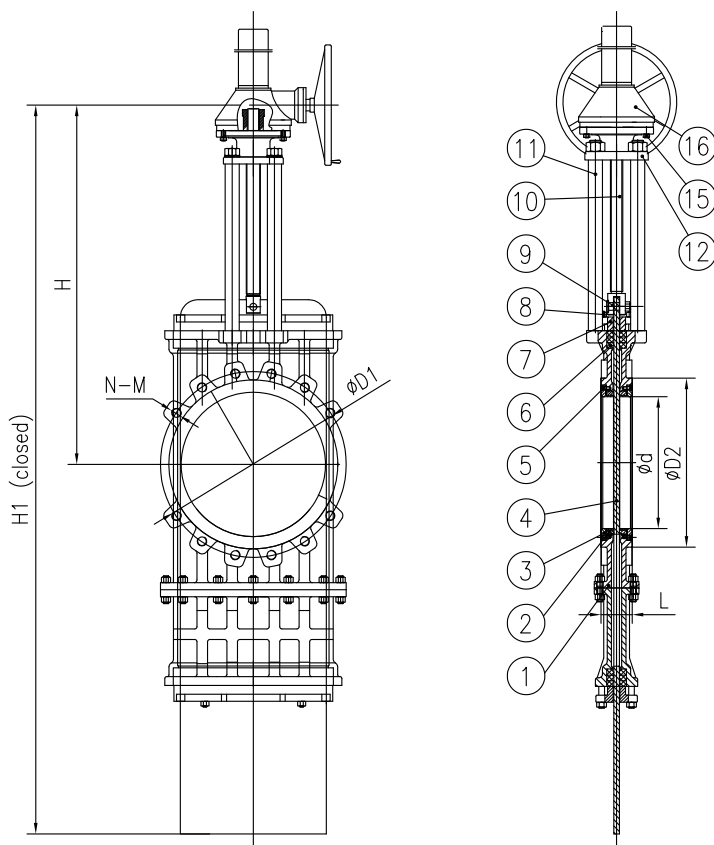

SIZE:DN200-DN600