



## Bi-directional seal Knife Gate Valve

## 1. General Description

### 1.1 Description

Resta Bi-directional seal Knife Gate Valve, steel body with 2 Replaceable seals structure knife gate valve, Flange protective cover to effectively protect the valve body, increasing valve life. This series of products is particularly suitable for the treatment of sludge

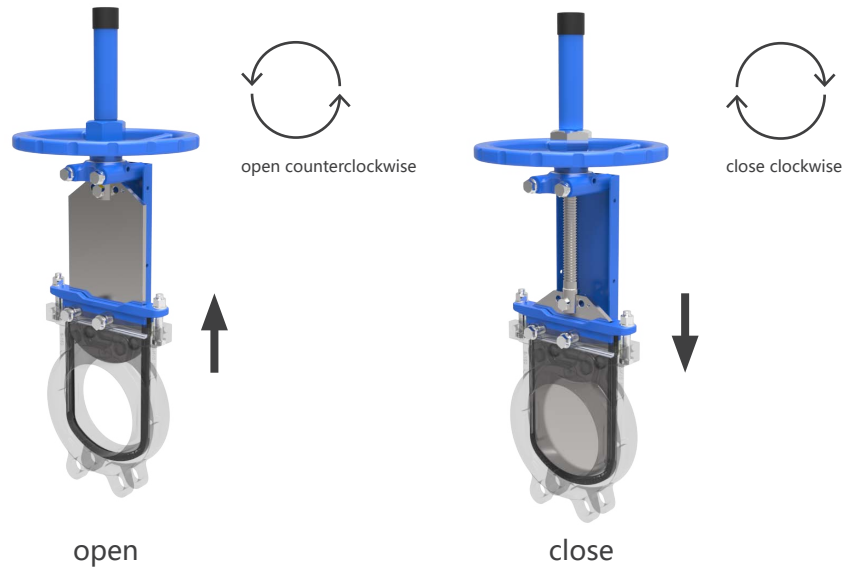

**P1.1**

### 1.2 Operation:

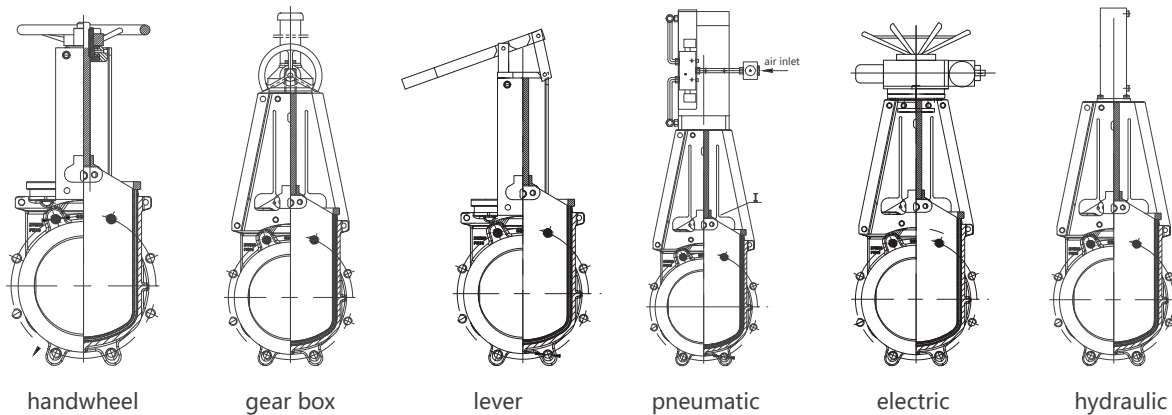

**P1.2**

## 2. Design standard

### 2.1 Medium:

<b>Model:</b>	RZ73X	
<b>Working Pressure:</b>	DN50-DN100	16bar
	DN125-DN200	10bar
	DN250-DN400	7bar
	DN450-DN550	5bar
	DN600-DN700	3bar
	DN800-DN900	2bar
	DN1000-DN1400	1bar
<b>Type:</b>	Wafer, Lug, Flange	
<b>Design Standard:</b>	MSS SP-81	
<b>Flange Standard:</b>	DIN3202 PN10/PN16	
<b>Face to face:</b>	MSS SP-81	
<b>Testing Standard:</b>	API-598	
<b>Operation:</b>	handwheel, electric, pneumatic, hydraulic, sprocket, electro-hydraulic, gear	
<b>Main material:</b>	GGG40	
<b>Disc material:</b>	SS304	
<b>Sealing material:</b>	NR, PU	
<b>Packing:</b>	PTFE, high water based, rubber packing, graphite, Aramind	
<b>Applicable medium:</b>	Applicable for sewage treatment, food, paper making, medicine and chemical industry, water, Oil, ores, chemicals, fruit juices, cereals, and other media.	
<b>Applicable principles:</b>	Due to rubber seal, Can not be used in medium with large amounts of particles, Mainly in the liquid content of more than 90% of the conditions used, For temperature please refer to page 13.	

#### Note:

- Different size working pressure was different, please make sure your order working pressure before order.
- Working pressure was different with flange standard pressure. (flange connection was PN10 not means the pipe inside pressure was 10bar)

## 3. Detail drawings and Data

### 3.1 Detail Drawing:

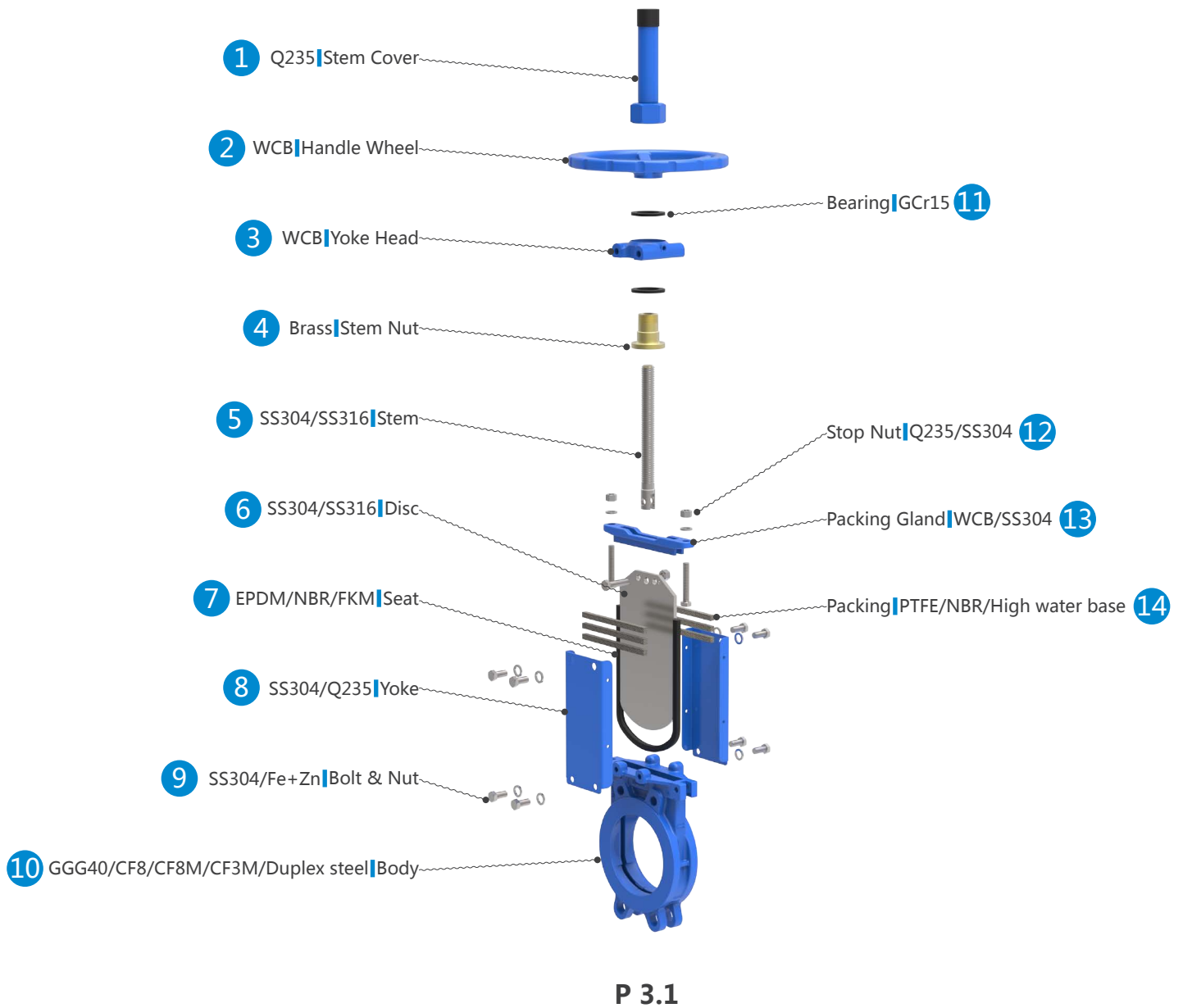

### 3.2 Detail Data:

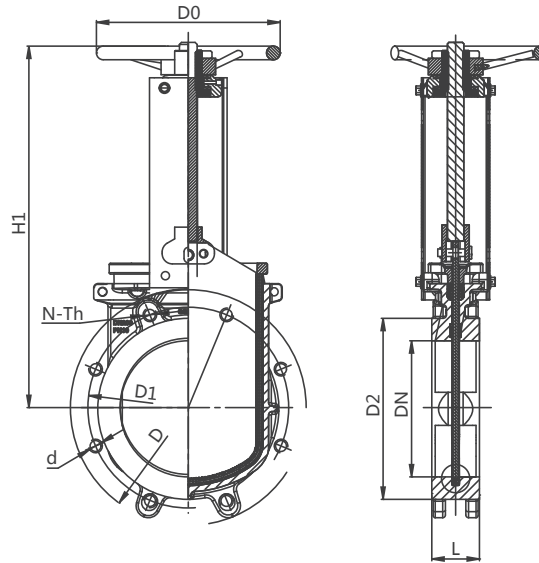

unit:mm

DIN2632 PN10									ANSI 150LB								
DN	L	D	D1	D2	D0	N-Th	d	H1	DN	L	D	D1	D2	D0	N-Th	d	H1
50	48	165	125	99	180	4-M16	Ø18	290	2"	48	152	121	92	180	4-5/8"	Ø19	260
65	48	185	145	118	200	4-M16	Ø18	330	2-1/2"	48	178	140	105	200	4-5/8"	Ø19	292
80	51	200	160	132	200	8-M16	Ø18	358	3"	51	191	153	127	200	4-5/8"	Ø19	320
100	51	220	180	156	240	8-M16	Ø18	378	4"	51	229	191	157	240	8-5/8"	Ø19	358
125	57	250	210	184	260	8-M16	Ø18	428	5"	57	254	216	186	260	8-3/4"	Ø22	395
150	57	285	240	211	280	8-M20	Ø23	490	6"	57	279	242	216	280	8-3/4"	Ø22	450
175	57	305	265	237	280	12-M20	Ø23	553	8"	70	343	299	270	300	8-3/4"	Ø22	532
200	70	340	295	266	300	8-M20	Ø23	588	10"	70	406	362	324	320	12-7/8"	Ø25	670
250	70	395	350	319	320	12-M20	Ø23	690	12"	76	483	432	381	350	12-7/8"	Ø25	758
300	76	445	400	370	350	12-M20	Ø23	815	14"	76	533	476	413	400	12-1"	Ø29	857
350	76	505	460	429	400	16-M20	Ø23	890	16"	89	597	540	470	450	16-1"	Ø29	946
400	89	565	515	480	450	16-M24	Ø27	980	18"	89	635	578	533	500	16-1 1/8"	Ø32	1023
450	89	615	565	530	500	20-M24	Ø27	1025	20"	114	699	635	584	500	20-1 1/8"	Ø32	Gear
500	114	670	620	582	500	20-M24	Ø27	1230	22"	114	750	692	641	-	20-1 1/4"	Ø35	Gear
550	114	725	680	638	-	20-M27	Ø30	1344	24"	114	813	750	691	-	20-1 1/4"	Ø35	Gear
600	114	780	725	682	-	20-M27	Ø30	1390	26"	114	870	806	749	-	24-1 1/4"	Ø35	Gear
700	127	895	840	794	-	24-M27	Ø30	1720	28"	127	927	864	800	-	28-1 1/4"	Ø35	Gear
800	127	1015	950	901	-	24-M30	Ø33	1862	30"	127	985	914	857	-	28-1 1/4"	Ø35	Gear
900	127	1115	1050	1001	-	28-M24	Ø27	1230	32"	127	1060	978	914	-	28-1 1/2"	Ø41	Gear
1000	149	1230	1160	1112	-	28-M33	Ø36	Gear	34"	127	1110	1029	965	-	32-1 1/2"	Ø41	Gear
1100	149	1340	1260	1220	-	28-M33	Ø36	Gear	36"	127	1170	1086	1022	-	32-1 1/2"	Ø41	Gear
1200	156	1455	1380	1328	-	32-M36	Ø39	Gear	38"	149	1240	1149	1073	-	32-1 1/2"	Ø41	Gear
									40"	149	1290	1200	1124	-	36-1 1/2"	Ø41	Gear
									42"	149	1345	1257	1194	-	36-1 1/2"	Ø41	Gear
									44"	149	1405	1314	1245	-	40-1 1/2"	Ø41	Gear
									46"	149	1455	1365	1295	-	40-1 1/2"	Ø41	Gear
									48"	156	1510	1422	1359	-	44-1 1/2"	Ø41	Gear
									50"	156	1570	1480	1410	-	44-1 3/4"	Ø51	Gear
									52"	156	1625	1537	1461	-	44-1 3/4"	Ø51	Gear
									54"	171	1685	1594	1511	-	44-1 3/4"	Ø51	Gear
									56"	171	1745	1651	1575	-	48-1 3/4"	Ø51	Gear

### 3.2 Detail Data:

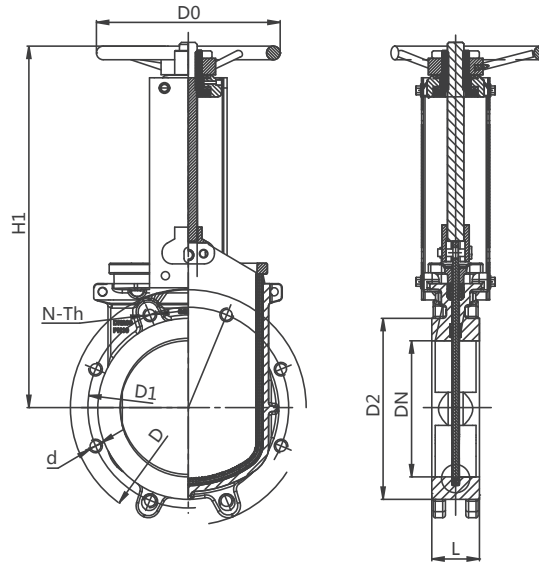

unit:mm

JIS 10K									Table D								
DN	L	D	D1	D2	D0	N-Th	d	H1	DN	L	D	D1	D2	D0	N-Th	d	H1
50	48	155	120	96	180	4-M16	Ø19	290	50	48	152	114	89	180	4-M16	Ø18	290
65	48	175	140	116	200	4-M16	Ø19	330	65	48	165	127	102	200	4-M16	Ø18	330
80	51	185	150	126	200	8-M16	Ø19	358	80	51	184	146	121	200	4-M16	Ø18	358
100	51	210	175	151	240	8-M16	Ø19	378	100	51	216	178	153	240	4-M16	Ø18	378
125	57	250	210	182	260	8-M20	Ø23	428	125	57	254	210	184.5	260	8-M16	Ø18	428
150	57	280	240	212	280	8-M20	Ø23	490	150	57	279	235	210	280	8-M16	Ø18	490
200	70	330	290	262	300	12-M20	Ø23	588	200	70	337	292	267	300	8-M16	Ø18	588
250	70	400	355	324	320	12-M22	Ø25	690	250	70	406	356	328	320	8-M20	Ø22	690
300	76	445	400	368	350	16-M22	Ø25	815	300	76	457	406	378	350	12-M20	Ø22	815
350	76	490	445	413	400	16-M22	Ø25	890	350	76	525	470	439	400	12-M24	Ø26	890
400	89	560	510	475	450	16-M24	Ø27	980	400	89	578	521	489	450	12-M24	Ø26	980
450	89	620	565	530	500	20-M24	Ø27	1025	450	89	640	584	553	500	12-M24	Ø26	1025
500	114	675	620	585	500	20-M24	Ø27	1230	500	114	705	641	610	500	16-M24	Ø26	1230
550	114	745	680	640	-	20-M30	Ø33	1344	550	114	762	699	663	-	16-M27	Ø30	1344
600	114	795	730	690	-	24-M30	Ø33	1390	600	114	825	756	721	-	16-M27	Ø30	1390
650	114	845	780	740	-	24-M30	Ø33	1595	700	127	895	845	794	-	20-M27	Ø30	1595
700	127	905	840	800	-	24-M30	Ø33	1720	750	127	996	927	889	-	20-M30	Ø33	1720
750	127	970	900	855	-	24-M30	Ø33	1862									
800	127	1020	950	905	-	28-M30	Ø33	1910									
850	127	1070	1000	955	-	28-M30	Ø33	-									
900	127	1120	1050	1005	-	28-M30	Ø33	-									
1000	149	1235	1160	1110	-	28-M30	Ø33	-									
1100	149	1345	1270	1220	-	28-M36	Ø33	-									
1200	156	1465	1380	1325	-	32-M36	Ø39	-									

## PN10 Threaded Hole and Through Hole

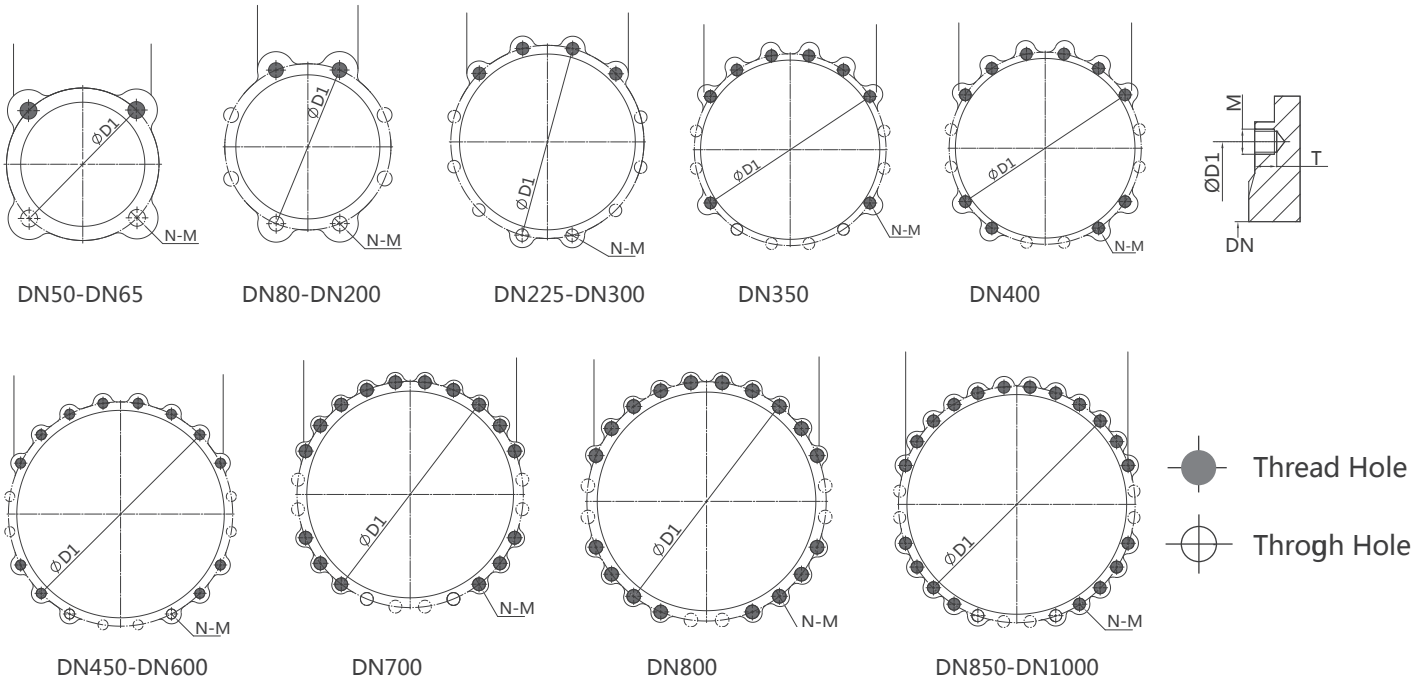

DN	D1	N	PN10		Thread Hole	Through Hole
			M	T		
50	125	4	M16	13	2	2
65	145	4	M16	13	2	2
80	160	8	M16	13	2	6
100	180	8	M16	13	2	6
125	210	8	M16	16	2	6
150	240	8	M16	16	2	6
200	295	8	M20	20	2	6
225	310	12	M20	20	4	8
250	350	12	M20	20	4	8
300	400	12	M20	20	4	8
350	460	16	M20	20	8	8
400	515	16	M24	24	10	6
450	565	20	M24	24	12	8
500	620	20	M24	24	12	8
550	680	20	M27	24	12	8
600	725	20	M27	27	12	8
700	840	24	M27	27	16	8
800	950	24	M30	30	18	6
900	1050	28	M30	30	20	8
1000	1160	28	M33	33	20	8

## 150LB Threaded Hole and Through Hole

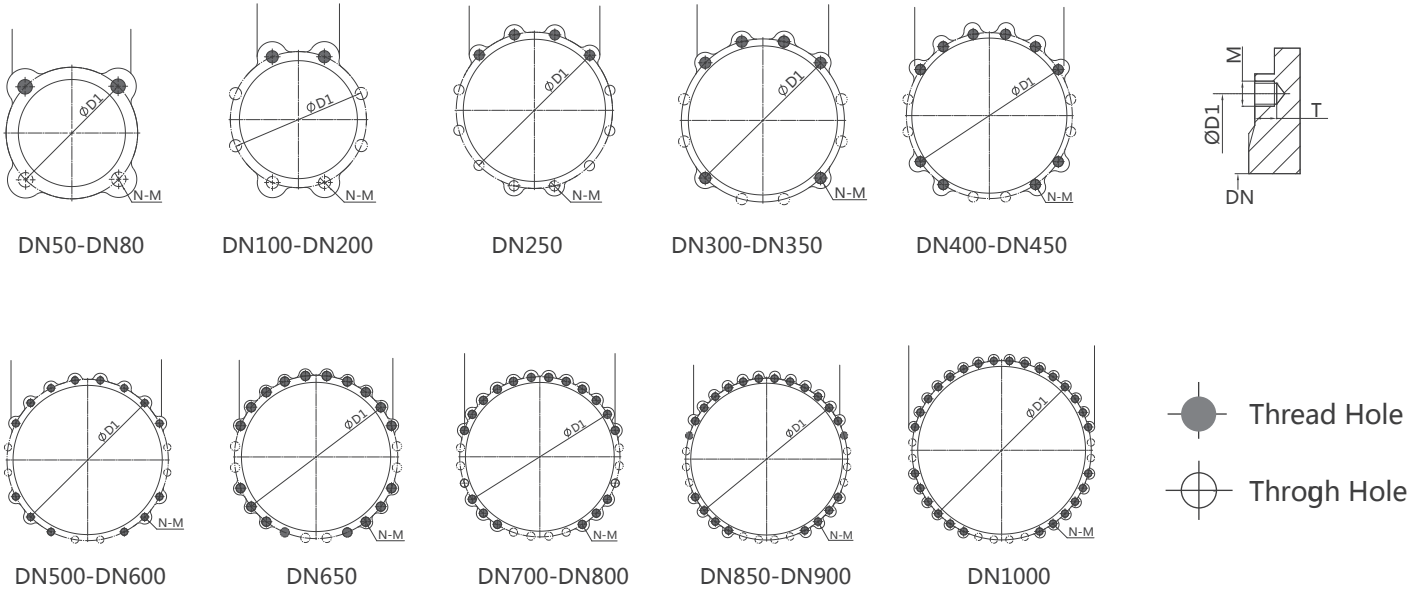

DN	D1	N	ANSI 150LB		Thread Hole	Through Hole
			M	T		
2"(DN50)	121	4	M5/8-11	13	2	2
2-1/2"(DN65)	140	4	M5/8-11	13	2	2
3"(DN80)	153	4	M5/8-11	13	2	2
4"(DN100)	191	8	M5/8-11	13	2	6
5"(DN125)	216	8	M3/4-10	16	2	6
6"(DN150)	242	8	M3/4-10	16	2	6
8"(DN200)	299	8	M3/4-10	20	2	6
10"(DN250)	362	12	M7/8-9	20	4	8
12"(DN300)	432	12	M7/8-9	20	6	6
14"(DN350)	476	12	M1-8	20	6	6
16"(DN400)	540	16	M1-8	24	10	6
18"(DN450)	578	16	M1 1/8-7	24	10	6
20"(DN500)	635	20	M1 1/8-7	24	14	6
22"(DN550)	692	20	M1 1/4-7	24	14	6
24"(DN600)	750	20	M1 1/4-7	27	14	6
26"(DN650)	806	24	M1 1/4-7	27	18	6
28"(DN700)	864	28	M1 1/4-7	27	18	10
30"(DN750)	914	28	M1 1/4-7	27	18	10
32"(DN800)	978	28	M1 1/2-6	30	18	10
34"(DN850)	1029	32	M1 1/2-6	30	22	10
36"(DN900)	1086	32	M1 1/2-6	30	22	10
40"(DN1000)	1200	36	M1 1/2-6	33	28	8



## 4. Handling and installation

### 4.1 Handling:



✓

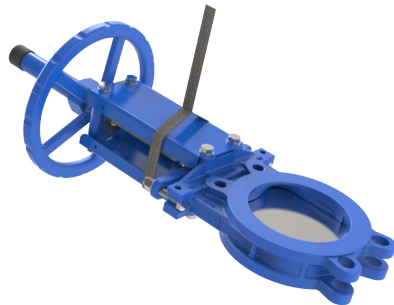

✗

**P 2.1**

Note:

- It is strongly required to use gloves, helmets and work shoes throughout handling
- It is best to use metal hooks to move the valve
- Do not carry valve with hooks or straps from the yoke

## 4. Handling and installation

### 4.2 Installation Direction:

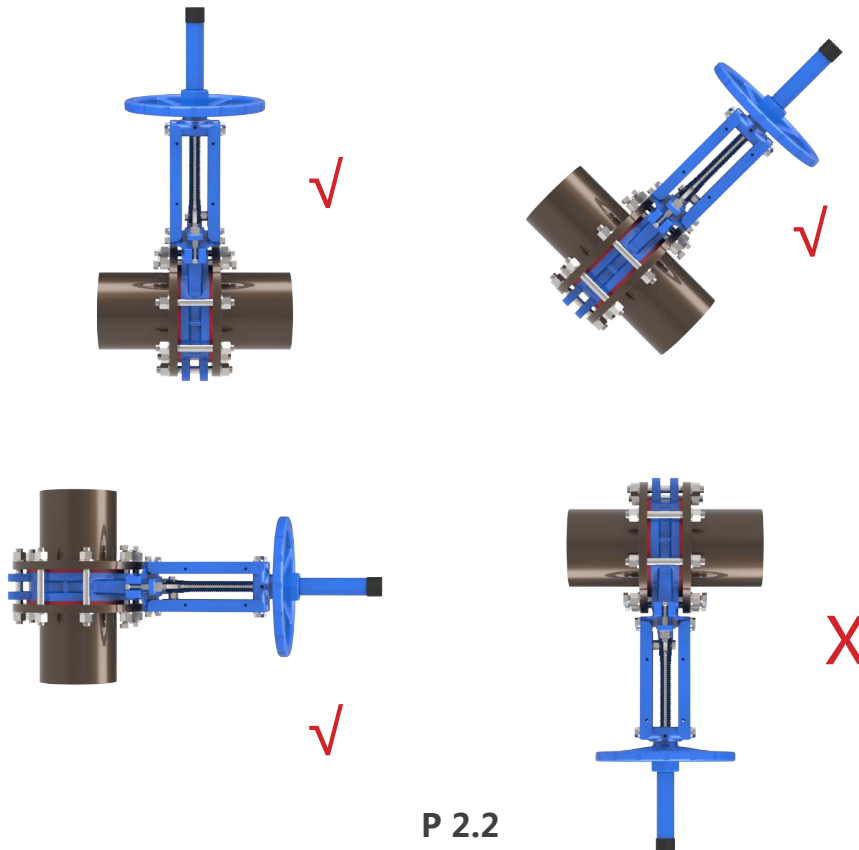

#### Note:

- It is strongly required to use gloves, helmets and work shoes throughout installation.
- Before installation, select the appropriate bolt, bolt selection, please refer to the data.
- Between the flange and the flange must have a gasket connection.

### 4.3 Installation Guide:



#### Note:

- Once the valve has been installed, check that all the screws and nuts have been correctly tightened and that the whole valve action system has been correctly adjusted (electrical connections, pneumatic connections, instruments...). Even if the valve has been assembled and tested at CHISUN during the handling and transport the screws on the packing gland tend to come loose and must be re-tightened.

## 5. Maintain and replace accessories

### 5.1 Maintain:

5.1.1 In the valve open state, regularly to the stem **5** and disc **6** oil. regularly tight bolts,make sure pipe flange position no leaking,make sure During the opening and closing of the valve, the Yoke **8** is not loose

5.1.2 Maintenance in use,every 30-40day(According to the actual conditions to increase and shorten the interval time In the valve open state oil between knife and packing gland,also the stem oil.

5.1.3 about storage:1.Store in an indoor or top-of-the-box building at the appropriate temperature.(-10°C~40°C)  
2.Recommended to store the valve in full or closed state.  
3.Do not store in a sunny environment



### 5.2 Replace accessories:

#### 5.2 Step 1

counterclockwise turning the wrench to disassemble the stem cover and nut. **1**



#### 5.2 Step 2

Remove the handwheel **2** and the positioning plate in the direction of the arrow



#### 5.2 Step 3

Remove the Yoke **8** Stem **5** Yoke head **3** Nut Bearing **11** and Disc **6** in the direction of the arrow

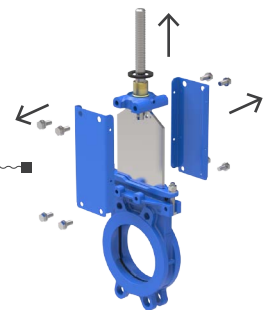

## 5. Maintain and replace accessories

### 5.2 Step 4

Move out Packing gland **13** washer and nut from the top of the valve body.

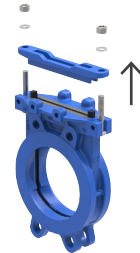

### 5.2 Step 5

Take out the Packing **14**

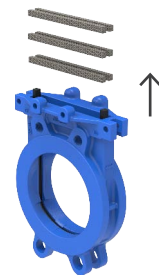

### 5.2 Step 6

Take out the U-type Seat **7**



### 5.2 Step 6

Install replacement Seat **7** and Packing **14**, Reinstall other components.

Repeat the above steps

## 6. Operation

### 6.1 Handwheel operation

Handwheel operation is one of the most commonly used valve opening methods, Usually used in small size valves(DN50-DN450).Turn the handwheel counterclockwise to turn on and turn it clockwise



### 6.2 Gear box operation

Gear box operation is one of the most commonly used valve opening methods, Usually used in big size valves(DN500 and bigger).Turn the handwheel counterclockwise to turn on and turn it clockwise,torque was smaller than handwheel.but turn on and off speed was slow.

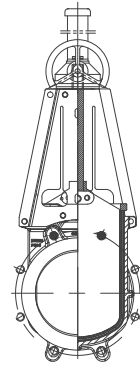

### 6.3 Lever operation

Gear box operation is one of the most commonly used valve opening methods, Usually used in big size valves(DN500 and bigger).Turn the handwheel counterclockwise to turn on and turn it clockwise,torque was smaller than handwheel.but turn on and off speed was slow.

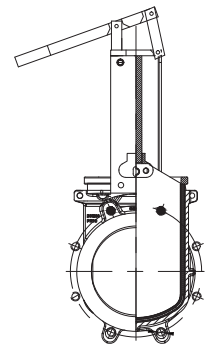

### 6.4 Pneumatic actuator

The default pneumatic actuator is a double acting actuator,Pneumatic actuators open and close pressure was 6bar-8bar.before use,open and close the actuators more than 2time.Gas source,The air supply requires clean and dry



### 6.5 Electric actuator

According to customer requirement,we supply different type and brand.

## 7. Flange installation Instructions

### 7.1 Flange installation:

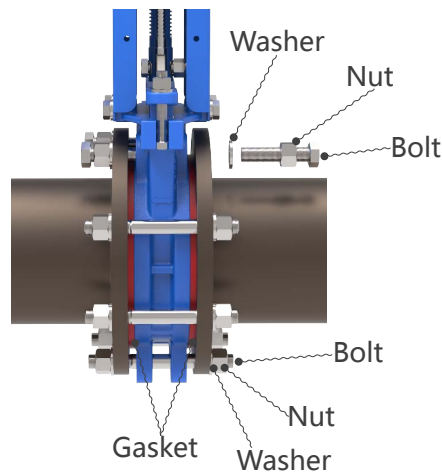

**Note:**

- Recommended to install as shown above picture,thread hole use washer-nut-bolt assembly,normal hole as washer-nut-bolt assembly.
- Do not install bolts with less quantity.

### 7.2 Torque data:

	DN50	DN65	dn80	DN100	DN125	DN150	DN200	DN250	DN300	DN350	DN400	DN450	DN500	DN600	DN700
Torque(N.M)	8	10	12	12	16	16	18	41	43	80	110	140	171	172	180
Thrust(N.M)															

## 8. Sealing material selection table

	A-excellent	B- good	C-ordinary	X-bad				
name	natural rubber	Styrene Butadiene	Nitrile Butadiene Rubber	Ethylene-Propylene-Diene Monomer	Silica	fluororubber	polyurethane	
code	NR	SBR	NBR	EPDM	Si	FKM	PU	
Min °C	-75	-55	-40	-55	-110	-30	-30	
max °C	70	70	100	125	225	250	100	
hard(shore A)	30~90	40~90	40~90	40~90	40~80	55~90	50~80	
tensile(kgf/cm <sup>2</sup> ) max	35	25	25	20	15	20	20	
mineral oil	X	X	A	X	B	A	A	
sulfuric acid	C	C	C	A	X	A	C	
toluene	X	X	X	X	X	A	A	
alcohol	B	B	A	A	X	A	X	
Ether	X	X	C	X	X	X	C	